



Fractional Single-Phase and Polyphase AC Induction Motors

This Manual Covers for the following WorldWide Electric Motors



WSSNV, WSS,
NAWSS, NAWSSSE



FM,FD



NT, NAT, NATE, NTJ,
NATJ, NATEJ

Installation, Operation, and Maintenance Product Manual

Table of Contents

Receiving Instructions	3
Warning	3
Storage	4
Removal From Storage	4
Handling	4
Location	4
Mounting	5
Power Supply	6
Electrical Connection	6
Startup	6
Protection Devices	7
Lubrication	7
Testing	7
Maintenance	7
Vibration Levels	7
Replaceable Parts	8
Warranty Policy	8
Wiring Terminal Samples	9

This manual includes procedures for the safe and proper transportation, storage, installation, connection, operation and maintenance of WorldWide Electric motors. For your protection, please read these instructions carefully before attempting to install, operate or service the motor. Please retain this manual in your files for future reference.

Receiving Instructions

- Inspect the shipping container for damage before accepting the motor from the carrier. Immediately report in writing any observed damage to the carrier.
- Check the motor nameplate data (HP, RPM, voltage, frame size, space heater, enclosure, etc.) before start-up.
- Turn shaft by hand to be certain it rotates freely and listen for any sounds of mechanical resistance like the fan rubbing on the fan cover. Check for debris or loose parts in the fan cover.

Warning

Safety precautions must be observed before installing, using, servicing and handling any WorldWide Electric motor. During the installation and operation of our motor in an industrial application, there is a danger of live electric parts and wires as well as hot surfaces and rotating parts. Therefore, please carefully read, fully understand, and heed all instructions, warnings, cautions and safety notices. Failure to do so could lead to personal injury, death and /or property damage.

Please review the following safety precautions:

- High voltage, rotating machinery and hot surfaces can cause serious or fatal injury if improperly installed. Only properly trained, qualified personnel should perform installation, operation and maintenance on equipment. Responsible personnel should be familiar with NEMA MG-2, National Electrical Code, CSA C22-100 (C.E.C), IEC 364 (prEN5011-1) and all state and local utility regulations and safety standards.
- When preparing to service the motor, all power sources to the motor and accessory devices must be de-energized and disconnected and made inoperative. Allow all rotating parts to come to a stop before servicing. Keep extremities, hair, clothing, foreign objects, etc. away from machinery. Replace Junction Box cover after connection.
- Before the motor is re-energized, make sure that all safety guards are in place and that the shaft key is removed before running the motor without a connected load.
- When working near machinery with high noise levels, proper protection must be used to reduce harmful effect to hearing.
- Automatic reset/thermostat protection should not be used where an unexpected automatic restart would be hazardous to personnel. Serious personal injury or death could occur.
- The frame of the machine must be grounded properly to protect against fatal injury to personnel. Lugs included in Junction Box.
- To protect against fatal injury to personnel, refer to NEC, CSA and local utility regulations and any applicable local codes.
- Provide proper safety guards for personnel against possible failure of motor-mounted brake, particularly on applications involving overhauling loads.

Storage

- For motors that will not be placed in service within six months of shipment date.
- Locate the motor indoors in a dry area (even temperature above -20°C), without sunlight, well vented, and free of dust or corrosive gas. Store motor off the floor on rubber mats, if possible. The motor should not be stored near heat or cold source (i.e. boiler/freezer). Motor should be stored in upright position.
- Measure and record the resistance of the winding insulation every 30 days of storage.
- The storage area should have less than 60% humidity and be free of shock or vibration. Vibration not to exceed 2 mils max.
- Treat unpainted flanges, shafts and fittings with a rust inhibitor.
- The shaft should be rotated 15 revolutions stopping at a different position every month to maintain proper distribution of grease in the bearing cavity.

Removal From Storage

- Remove all packing material.
- Measure and record the winding insulation resistance at the time of removal from storage. The insulation resistance must not be less than 50% from the initial reading recorded when the motor was placed into storage. A decrease in resistance indicates moisture in the windings and necessitates electrical or mechanical drying before the motor can be placed into service.

Handling

- Use correct material handling equipment to avoid injury. Use caution when removing the motor from its packaging. Sharp corners may exist on motor shaft, motor key, sheet metal and other surfaces.

Location

- ODP motors are intended for use indoors where atmosphere is relatively clean, dry, corrosive free & well vented.
- Totally enclosed motors may be installed where dirt, moisture, chemicals and/or dust are present in an outdoor location.
- Standard TEFC motors are suitable for use in ambient temperatures between -20°C to -40°C with low temperature grease to $+40^{\circ}\text{C}$ and at elevations at or below 1000 meters (3300 ft ASL). For temperatures higher or lower, please contact WorldWide Electric office.

Mounting

- Make certain that the underside of the motor feet and/or the flange is clean and free of dirt. It is imperative that the motor be level. Remove any masking materials or any rust inhibitive coating from the mounting surface and shaft.
- All ball bearing motors can be mounted in all positions shown in NEMA MG1-4.03, provided that the surface is stable and rigid, and the drain holes are located properly.
- The motor should be used only with coupling systems which are elastic with respect to center offset, angular displacement, longitudinal shift and torsional strain. Rigid coupling systems are not permissible (unless previously agreed).
- When using a direct coupling check center offset and angular offset with screwed on test arm and dial gauge at normal operating temperature. The following deviations should not be exceeded:
 - Center offset (radial measurement) 0.03 mm in 2 pole motors. 0.05 mm in motors with more than 2 poles. (the dial shows twice the value of the deviation).
 - Angular offset (axial measurement) 0.10 mm.
- The motor must be securely installed to a rigid foundation or mounting surface to minimize vibration and maintain alignment between the motor and the shaft load. Failure to do so will cause vibration, misalignment and /or bearing damage.
- Remove drain plugs from the end shield or frame on totally enclosed motors. It is critical that the motor be mounted with these at the lowest point of the frame. If the motor is to be mounted with the feet in any position except down, these must be relocated to the appropriate position. Contact WorldWide Electric for advice.
- Mount the pulley or half coupling to the motor shaft using non-impact method. Do not hammer on the motor shaft as this will cause brinelling of the bearing, leading to premature failure of the motor.
- The motor is balanced using a half key; therefore, the motor pulley or half coupling should also be balanced with a half key. After mounting the coupling or the belt and pulleys, a guard must be placed over all the moving parts to protect against accidental contact or injury.
- Do not over tighten the belts as this will lead to an excessive overhung load on the motor bearings, causing a significant reduction in bearing life and premature failure.
- Make certain that there is adequate space around the motor for ventilation. If using a belt pulley, the ventilation opening at the rim of the pulley is essential for the motor's cooling. All ventilation opens must not be obstructed, and any wall or divider should be mounted a minimum of 30 inches (762mm) away from the motor.

Power Supply

- The wiring of the motor and controls as well as the grounding and overload protection should be performed in accordance with National Electrical Code, CSA C22-100 (C.E.C.) and all local and utility regulations and safety standards. Installation should be done only by properly qualified personnel.
- Nameplate voltage and frequency should agree with the power supply. Motor will operate satisfactorily with supply voltage within 10% of the nameplate value or frequency within 5% combined variation not to exceed 10%.

Electrical Connection

- Connect the motor as shown on the connection diagram on the motor nameplate. Be sure to identify the proper wiring diagram for the supply voltage of motor you are installing. If you have difficulty determining the proper wiring diagram for your motor, please contact WorldWide Electric for assistance. If this motor is installed as part of a motor control drive system, connect and protect the motor according to the control manufacturer's diagram. The wiring, fusing and grounding must comply with the National Electrical Code or IEC and local codes.
- **NOTE:** WIRE NUTS ARE NOT AN APPROVED TERMINATION METHOD

Start Up

- Disconnect the load when starting the motor, making sure the key is removed from the shaft. Check direction of rotation. If rotation must be changed allow the motor to stop completely. Interchange any two incoming power leads of a three-phase motor to change the direction of the rotation. See wiring diagram.
- Note: If improper rotation direction is detrimental to the load, check the rotation or 'bump' the motor prior to coupling the load to the motor shaft. When the motor is coupled to the load and started, it should start quickly and run smoothly. If not, stop the motor immediately and determine the cause. Possible causes are low voltage at the motor, motor connections are not correct, or the load is too heavy. Check the motor current after a few minutes of operation and compare the measured current with the nameplate rating.
- Motor with a service factor greater than 1.0 S.F. can be operated continuously with the current not exceeding the nameplate value multiplied by the service factor.
- Example: $18.1 \text{ amps} \times 1.15 \text{ S.F.} = 20.825 \text{ full load amps.}$
- When using AC motors with frequency inverters, be certain that the motors maximum speed rating is not exceeded.
- Pay special attention to the temperature reading on the motor, the outside temperature or skin temperature of the motor, as well as monitoring, and measure the inside temperature of the motor. Note: the bearing temperature should not exceed 60°C. Surface temperature may exceed 90°C (194°F)
- **WARNING:** Do not touch the exterior of an operating motor. The motor may be hot enough to be painful or cause injury.

Protection Devices

- Thermal Reset Overloads are fitted to motors. If overload should trip motor should be allowed to cool before the overload is reset. To reset the overload, press the red button mounted on the motor terminal box. Supply to the motor should be disconnected before restart is attempted and cause for the overload should be investigated.

Lubrication

- Bearings are greased for life and need no further maintenance. This means that greasing can only be carried out during general overhauls when the motor is disassembled.

Testing

- If the motor has been in storage for a long period of time or has been subjected to adverse moisture or extremely dusty/dirty conditions, it is best to check the insulation resistance of the stator windings with a megohmmeter. Depending on the length and conditions of storage it may be necessary to change out bearings. If resistance is lower than 1 megohm, the windings should be dried in one of the following manners:
- Bake in oven at temperature below 194°F until the insulation resistance becomes constant for a minimum of 30 minutes. Constantly monitor the conditions.
- With the rotor locked, apply low voltage (approximately 10% nameplate voltage) and gradually increase current through windings until temperature measured with thermometer reaches 87°C (188°F). Do not exceed this temperature. Maintain this temperature until the insulation resistance remains constant 30 minutes.

Maintenance

- When the motor is in operation, examine the motor at regular intervals (about 500 hours). Make sure the ventilation openings are clear and unobstructed.
- Check the condition of shaft seals and replace if necessary.
- Check the condition of connections and mounting and assembly bolts.
- Check the bearing condition by listening for any unusual noise, vibration measurement, bearing temperature, inspection of spent grease or SPM bearing monitoring.

Vibration Levels

- Note: Acceptable vibration levels at no load condition.
- NEMA MG1-7
- 2-6 Pole: 0.15 in/s peak
- 8 Pole: 0.12 in/s peak

Replaceable Parts

- In maintaining your WorldWide Electric motor, use genuine factory replacement parts as recommend by WorldWide Electric Corp. Failure to do so might cause damage or failure to the motor.
- When ordering renewal parts please specify complete nameplate information such as: model, HP, type, frame, voltage, serial number, RPM and enclosure. Call us at 1-800-808-2131 between the hours of 8:00 AM- 6:00 PM to order.

Warranty Policy

- All WorldWide Electric motors are warranted against defect in workmanship and materials and carry full warranties.
- WorldWide Electric shall, at its sole option and expense, repair or replace, F.O.B. Warehouse, any such motor or part which is defective within the warranty period. Repair or replacement constitutes complete fulfillment on WorldWide Electric part. The nature and length of the warranty will depend upon the motor and is set forth below:

WORLDWIDE ELECTRIC FRACTIONAL HP MOTORS	
General Purpose Motors	Two (2) years from date of sales (invoice)
Stainless Steel / Washdown Duty Motors	Three (3) years from date of sales (invoice)
Jet Pump Motors	Two (2) years from date of sales (invoice)
Permanent Magnet DC Motors	One (1) year from date of sales (invoice)
Farm Duty Motors	Two (2) years from date of sales (invoice)

WARNING: Before you install, operate, or perform maintenance, observe all safety warnings so as to protect any personnel from possible injuries from high voltage, hot surfaces, improper handling and rotating parts. Never disable or by-pass any safety devices.

Wiring Terminal Samples

NT, NTJ Dual Voltage Capacitor Start/Induction Run (1/3 - 1 HP)

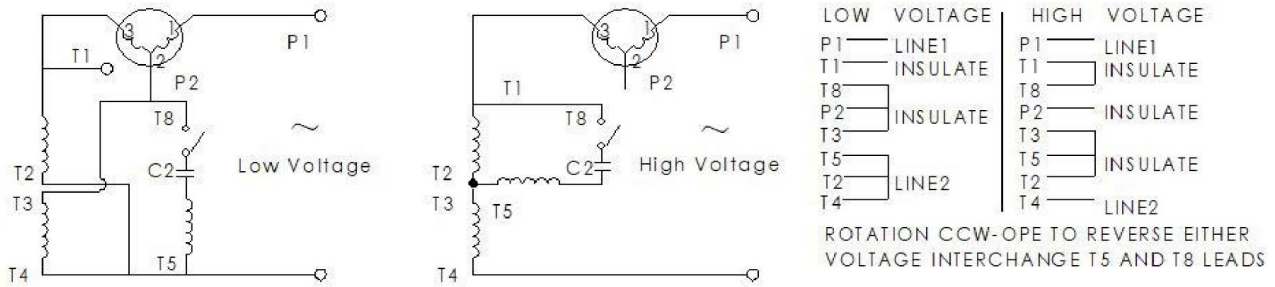

NT, NTJ Dual Voltage Capacitor Start/Capacitor Run (1.5 - 2 HP)

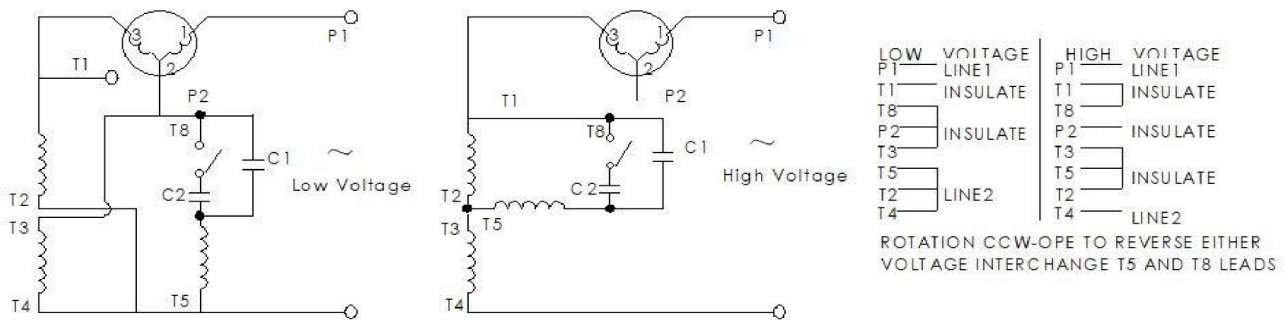

NAT, NATE, NATJ, NATEJ, WSSNV, WSS, NAWSS, NAW SSE and SSPE 9 Leads; Dual Voltage & Voltage Ratio 1 to 2, Wye connected

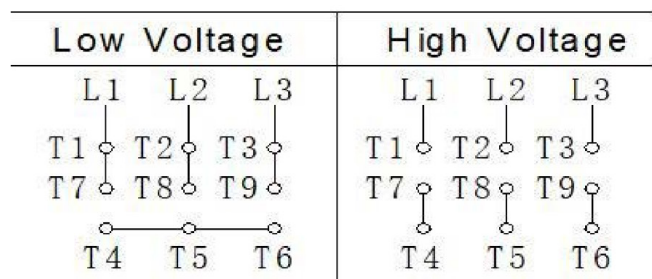
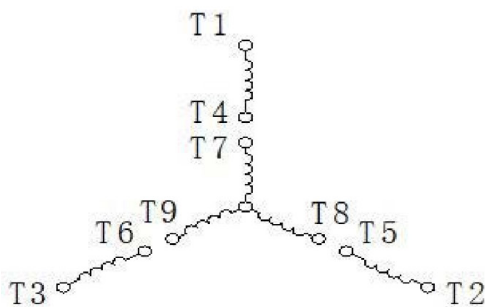

Wiring Terminal Samples

FM Dual Voltage Capacitor Start/Induction Run (1/3 – 1 HP)

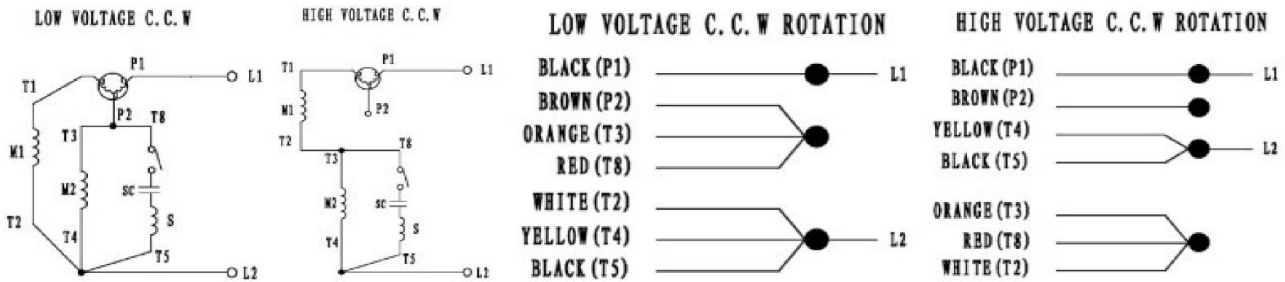

Rotation CCW-OPE to reverse direction interchange Black (T5) and Red (T8) leads.

FM Dual Voltage Capacitor Start/Capacitor (1.5 – 2 HP)

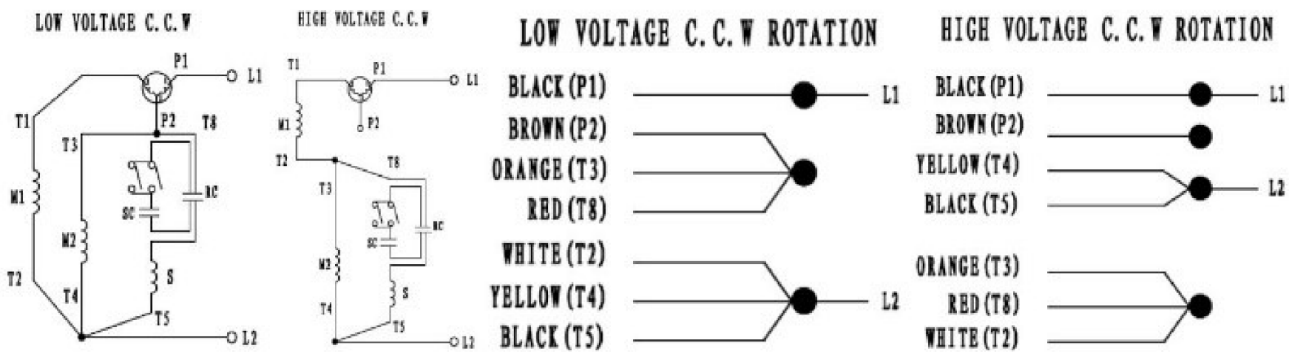

Rotation CCW-OPE to reverse direction interchange Black (T5) and Red (T8) leads.

FD – All FD motors are 4-Lead, 208-230V

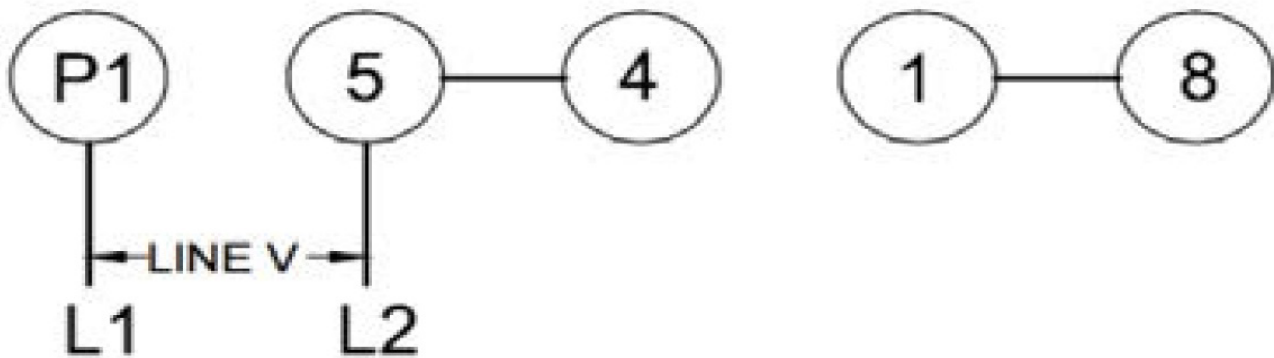

Connected for CCW rotation facing opposite drive end. To reverse rotation interchange lead 5 & 8.



WorldWide[®]
ELECTRIC CORPORATION

WorldWide Electric Corporation

3540 Winton Place, Rochester, NY 14623

24/7 Phone: (800) 808 - 2131

24/7 Service: (844) WWE - SERV

Email: CustomerService@worldwideelectric.com
worldwideelectric.com